

Data Sheet

Customer:

Product: Metal Glazed Leaded Resistor—MGR Series

Sizes.: 0623/0932/1145/1550

Issued Date: 13-Apr-20

Edition: REV.A4



VIKING TECH CORPORATION
光頤科技股份有限公司
No.70, Guangfu N. Rd., Hukou
Township, Hsinchu County
303, Taiwan (R.O.C)

TEL:886-3-5972931
FAX:886-3-5972935•886-3-5973494
E-mail:sales@viking.com.tw

VIKING TECH CORPORATION KAOHSIUNG BRANCH
光頤科技股份有限公司高雄分公司
No.248-3, Sin-Sheng Rd., Cian-Jhen Dist., Kaohsiung,
806, Taiwan

TEL:886-7-8217999
FAX:886-7-8228229
E-mail:sales@viking.com.tw

VIKING ELECTRONICS (WUXI) CO., LTD.
光頤電子(無錫)有限公司
No.22 Xixia Road, Machinery & Industry Park,
National Hi-Tech Industrial Development Zone
of Wuxi, Wuxi, Jiangsu Province, China
Zip Code:214028
TEL:86-510-85203339
FAX:86-510-85203667•86-510-85203977
E-mail:china@viking.com.tw

Produced by (QC)	Checked (QC)	Approved by (QC)	Prepared by (Sales)	Accepted by (Customer)
13-Apr-20	13-Apr-20	13-Apr-20	13-Apr-20	
<i>Kris Chen</i>	<i>Ben Chang</i>	<i>Ben Chang</i>		

**Metal Glazed Ledged Resistor
Metal Glazed Ledged Resistor**

Scope

- Coat-Insulated megohm fixed resistors (Metal Glazed)
- High voltage surge resistors

Construction

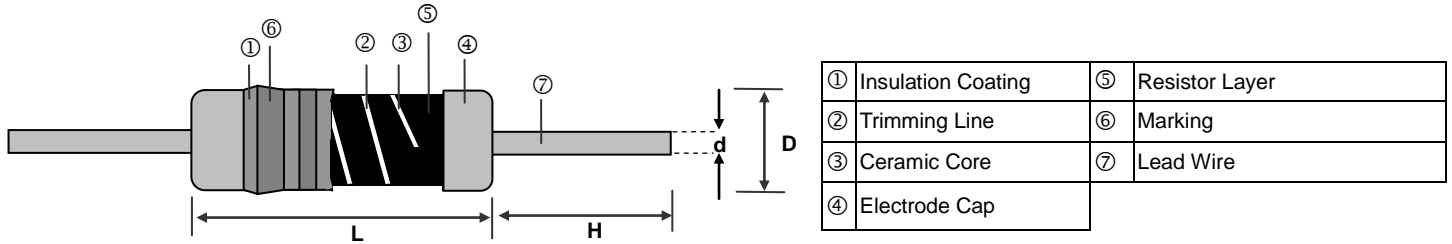

Dimensions

Unit: mm

Type	L	D	H	d
MGR0623	6.3±0.5	2.3±0.3	28±2.0	0.55±0.03
MGR0932	9.0±0.5	3.2±0.5	26±2.0	0.65±0.03
MGR1145	11.5±1.0	4.5±0.5	35±2.0	0.78±0.03
MGR1550	15.5±1.0	5.0±0.5	32±2.0	0.78±0.03

Part Numbering

MGR	0932	F	T	F	U	1004	S
Product Type	Dimensions (LxD)	Resistance Tolerance	Packaging Code	TCR (PPM/C)	Power Rating	Resistance	Special
	0623: 6.3x2.3 0932: 9.0x3.2 1145: 11.5x4.5 1550: 15.5x5.0	F: ±1% G: ±2% J: ±5%	A: Ammo T: Taping Reel	E: ±100 F: ±200	V: 1/4W U: 1/2W T: 1W S: 2W R: 3W	1003: 100KΩ 1004: 1MΩ 1007: 1GΩ	S: Silicone Resin E: Epoxy Resin

Metal Glazed Ledged Resistor

Derating Curve

Surface Temp Rise

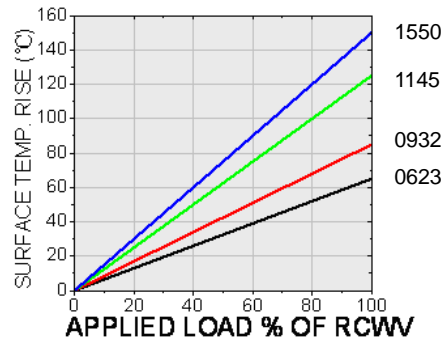
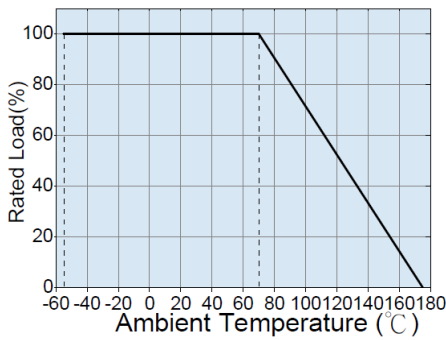

Standard Electrical Specifications

Item Type	Power Rating at 70°C	Operating Temp. Range	Max. Working Voltage	Max. Overload Voltage	Dielectric Withstanding Voltage		Resistance Range			TCR (PPM/°C)	Measured
					Silicone Resin	Epoxy Resin	±1%	±2%	±5%		
0623	1/4W	-55 ~ +175°C	DC1600V AC1150V	DC2000V AC1500V	400V	500V	10KΩ~100MΩ		1KΩ~100MΩ	±100	DC100V 1K≤R≤1M DC1000V 1M≤R
							101MΩ~1GΩ			±200	
0932	1/2W		DC3500V	4000V	500V	700V	10KΩ~100MΩ		1KΩ~100MΩ	±100	
							101MΩ~1GΩ			±200	
1145	1W		DC4500V	5000V	500V	1000V	1KΩ~100MΩ			±100	
							101MΩ~1GΩ			±200	
1550	2W		DC7000V	14000V	700V	1200V	1KΩ~100MΩ			±100	
							101MΩ~1GΩ			±200	

High Power Rating Electrical Specifications

Item Type	Power Rating at 70°C	Operating Temp. Range	Max. Working Voltage	Max. Overload Voltage	Dielectric Withstanding Voltage		Resistance Range			TCR (PPM/°C)	Measured
					Silicone Resin	Epoxy Resin	±1%	±2%	±5%		
0623	1/2W	-55 ~ +175°C	DC1700V	2500V	400V	500V	10KΩ~100MΩ		1KΩ~100MΩ	±100	DC100V 1K≤R≤1M DC100V 1K≤R≤1M DC1000V 1M≤R DC1000V 1M≤R
							101MΩ~1GΩ			±200	
0932	1W		DC4000V	4500V	500V	700V	10KΩ~100MΩ			±100	
							101MΩ~1GΩ			±200	
1145	2W		DC7000V	14000V	700V	1200V	10KΩ~100MΩ			±100	
							101MΩ~1GΩ			±200	
1550	3W		DC10000V	14000V	700V	1200V	10KΩ~100MΩ			±100	
							101MΩ~1GΩ			±200	

Operating Voltage= $\sqrt{P \cdot R}$ or Max. operating voltage listed above, whichever is lower.
 Overload Voltage= $2.5 \cdot \sqrt{P \cdot R}$ or Max. overload voltage listed above, whichever is lower.

Silicone Resin coating color : Brown (Flame-Proof)

Epoxy Resin coating color : Light Blue

Metal Glazed Leaded Resistor

Environmental Characteristics

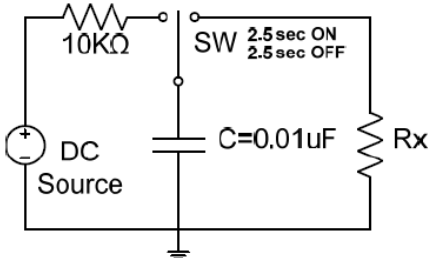
Item	Requirement	Test Method								
Temperature Coefficient(T.C.R)	As Spec	Resistance value at room temperature and room temperature+125°C								
Short Time Overload	±(1.0%+0.05Ω)	JIS-C-5201-1 5.5 RCWV*2.5 or Max. overload voltage whichever is lower for 5 seconds								
Insulation Resistance	±10,000MΩ Over	MIL-STD-202F Method 302 500±50V DC During 1 min V-Block method								
Endurance	±(3.0%+0.05Ω)	MIL-STD-202F Method 108A 70±2°C, RCWV for 1000 hrs with 1.5 hrs "ON" and 0.5 hrs "OFF"								
Humidity	±(5.0%+0.05Ω)	MIL-STD-202F Method 103B 40±2°C, 90~95% R.H., for 1000 hrs (for epoxy resin) with 1.5 hrs "ON" and 0.5 hrs "OFF"								
Dielectric Withstanding Voltage	By Type	MIL-STD-202F Method 301 In V-Block for 1 minute								
Intermittent Overload	±(1.0%+0.05Ω)	JIS-C-5201-1 5.8 4 times RCWV for 10000 cycles with 1sec "ON" and 25 sec "OFF"								
Resistance To Soldering Heat	±(1.0%+0.05Ω)	260°C±5°C for 2±1 seconds								
Terminal Strength	Tensile: ≥ 2.5kg	Direct Load for 10 sec. In the direction off the terminal leads								
Resistance to Solvent	No abnormality in coatings and markings	IPA for 5±0.5 Min. with ultrasonic								
Anti Surge characteristics	± (10% + 0.05Ω)	Discharge Test : 0.01uf capacitor Discharge Pulse 10 time. (1 pulse / 5sec. max) 								
		<table border="1"> <thead> <tr> <th>Type</th> <th>0623</th> <th>0932</th> <th>1145 / 1550</th> </tr> </thead> <tbody> <tr> <td rowspan="3">Voltage</td> <td rowspan="3">3KV</td> <td>1K≤R<10K:5KV</td> <td rowspan="3">10KV</td> </tr> <tr> <td>10K≤R<100K:7KV</td> </tr> <tr> <td>100K≤R:10KV</td> </tr> </tbody> </table>	Type	0623	0932	1145 / 1550	Voltage	3KV	1K≤R<10K:5KV	10KV
Type	0623	0932	1145 / 1550							
Voltage	3KV	1K≤R<10K:5KV	10KV							
		10K≤R<100K:7KV								
		100K≤R:10KV								

RCWV(Rated continuous working voltage)= √(P*R) or Max. Operating voltage whichever is lower

■Storage Temperature: 15~28°C; Humidity < 80%RH

Metal Glazed Ledged Resistor

■Taping/Packing Specifications

1. Standard Type (Reel & Ammo)

Packing Methods

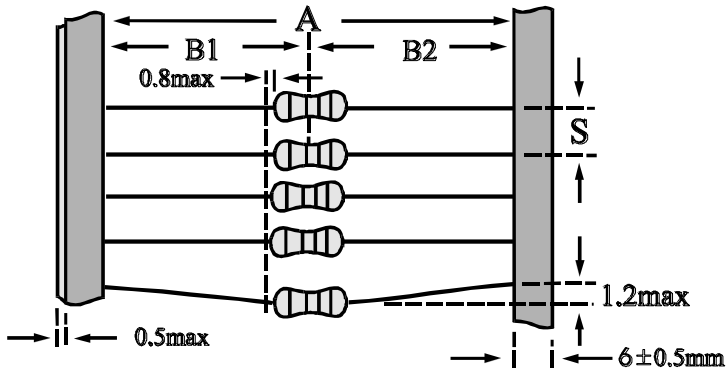

Reel Packing

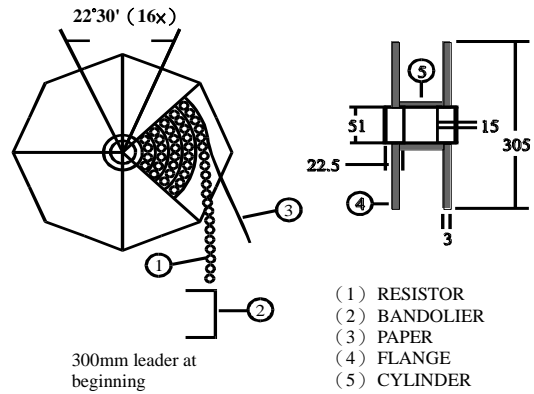

Ammo Packing

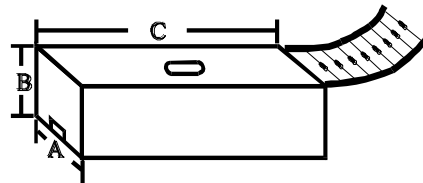

Unit: mm

Packaging Type	Packing Methods			Reel Packing		Ammo Packing			
	A	B1-B2 Max	S	Across Flange (A)	Qty	A	B	C	Qty
0623 (Epoxy Coating)	52+1/-0	1.2	5±0.3	72	5,000	79±2	100±3	257±5	5,000
	26+0.5/-0	1.0				52±2	109±3	252±5	
0623 (Silicone Coating)	52+1/-0	1.2	5±0.3	72	5000	82±2	108±3	258±5	
0932	52+1/-0	1.2	5±0.3	72	2,500	79±2	58±3	257±5	1,000
1145	52+1/-0	1.5	5±0.3	95	2,000	103±2	82±3	262±5	1,000
	73+1/-0								
1550	52+1/-0	1.5	10±0.8	95	1,000	103±2	96±3	265±5	1,000
	73+1/-0								

Metal Glazed Ledged Resistor

■ Marking & Resistance Tolerance

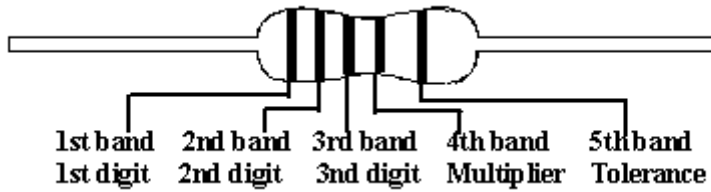
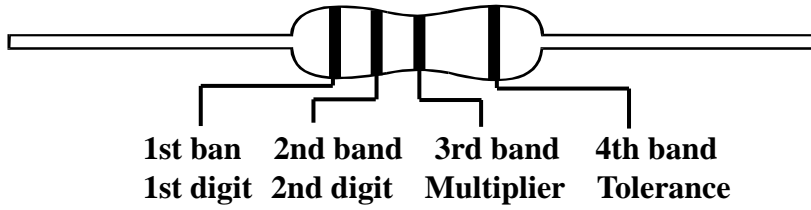

Color	Digit	Multiplier	Tolerance	
Without	-	-	-	-
Silver	-	10 ⁻²	±10%	K
Gold	-	10 ⁻¹	±5.0%	J
Black	0	10 ⁰	-	-
Brown	1	10 ¹	-	-
Red	2	10 ²	±2.0%	G
Orange	3	10 ³	-	-
Yellow	4	10 ⁴	-	-
Green	5	10 ⁵	-	-
Blue	6	10 ⁶	-	-
Violet	7	10 ⁷	-	-
Grey	8	10 ⁸	-	-
White	9	10 ⁹	-	-

±5.0%	E-24	1.0	1.1	1.2	1.3	1.5	1.6	1.8	2.0	2.2	2.4	2.7	3.0	3.3	3.6	3.9	4.3	4.7	5.1	5.6	6.2	6.8	7.5	8.2	9.1	
±2.0%																										
±1.0%																										