

Data Sheet

Customer: _____

Product: Automotive Grade Chip Resistor (Wide Terminal) –
CRW..A Series

Size: 0508/0612/1020/1225

Issued Date: 10-Mar-21

Edition: REV.A2



VIKING TECH CORPORATION
光頡科技股份有限公司

No.70 Guangfu N. Rd., Hukou
Township, Hsinchu County 303,
Taiwan

TEL:886-3-5972931

FAX:886-3-5972935•886-3-5973494

E-mail:sales@viking.com.tw

VIKING TECH CORPORATION KAOHSIUNG BRANCH
光頡科技股份有限公司高雄分公司

No.248-3, Sin-Sheng Rd., Cian-Jhen Dist., Kaohsiung,
806, Taiwan

TEL:886-7-8217999

FAX:886-7-8228229

E-mail:sales@viking.com.tw

VIKING ELECTRONICS (WUXI) CO., LTD.
光頡電子(無錫)有限公司

No.22 Xixia Road, Machinery & Industry Park,
National Hi-Tech Industrial Development Zone
of Wuxi, Wuxi, Jiangsu Province, China
Zip Code:214028

TEL:86-510-85203339

FAX:86-510-85203667•86-510-85203977

E-mail:china@viking.com.tw

Produced by (QC)	Checked (QC)	Approved by (QC)	Prepared by (Sales)	Accepted by (Customer)
10-Mar-21	10-Mar-21	10-Mar-21	10-Mar-21	
Susan Huang	J.C. Liu	J.C. Liu		

Automotive Grade Chip Resistor (Wide Terminal)-CRW..A Series



Scope

– This specification applies to all sizes of rectangular-type fixed chip resistors with Ruthenium-base as material.

Features

- AEC-Q200 Compliance
- Highly reliable multilayer electrode construction
- Compatible with all soldering process
- 100% CCD inspection

Construction

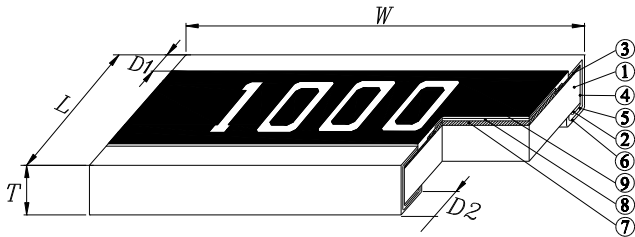

Applications

- Automotive Industry
- Telecommunication Equipments
- Radio and Tape Recorders, TV Tuners
- Digital Cameras, Watches, Pocket Calculators
- Computers, Instruments
- Medical Equipment

① Alumina Substrate	④ Edge Electrode	⑦ Resistor Layer
② Bottom Electrode	⑤ Barrier Layer	⑧ Primary Overcoat
③ Top Electrode	⑥ External Electrode	⑨ Secondary Overcoat

Dimensions

Type	Size (Inch)	L (mm)	W (mm)	T (mm)	D1 (mm)	D2 (mm)
CRW08	0508	1.25±0.10	2.00±0.10	0.55±0.10	0.30±0.15	0.30±0.15
CRW08(Jumper)					0.20±0.15	
CRW62	0612	1.55±0.10	3.00±0.15	0.55±0.10	0.25±0.15	0.40±0.15
CRW62(Jumper)						
CRW20	1020	2.45±0.15	5.00±0.10	0.60±0.15	0.35±0.20	0.70±0.20
CRW20(Jumper)					0.45±0.20	
CRW25	1225	3.20±0.20	6.40±0.15	0.65±0.15	0.40±0.20	1.10±0.20
CRW25(Jumper)					0.50±0.20	

Part Numbering

CRW	25	F	C	4	---20R
Product Type	Dimensions	Resistance Tolerance	Function Code	Packaging Code	Resistance
CRW	08: 0508 62: 0612 20: 1020 25: 1225	D: $\pm 0.5\%$ F: $\pm 1\%$ J: $\pm 5\%$	A: Automotive Grade C: High Power & Automotive Grade	4: 7" Reel 4Kpcs 7: 7" Reel 5Kpcs	---20R: 20 Ω --- 1R2: 1.2 Ω --- -0R: 0 Ω "-" to fill up 6 spaces

Recommend Land Pattern

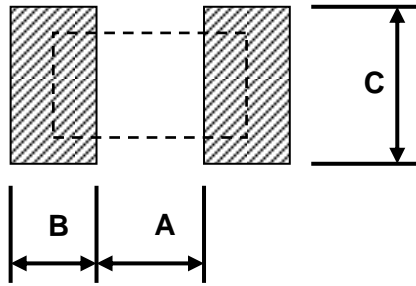

Type	A (mm)	B (mm)	C (mm)
CRW08	0.55	0.90	2.00
CRW62	0.70	0.80	3.20
CRW20	1.00	1.20	5.00
CRW25	1.00	2.00	7.00

Derating Curve

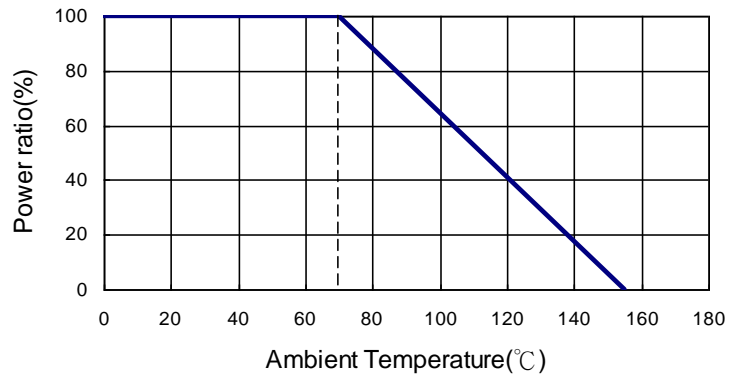

Soldering Condition (IPC/JEDEC J-STD-020)

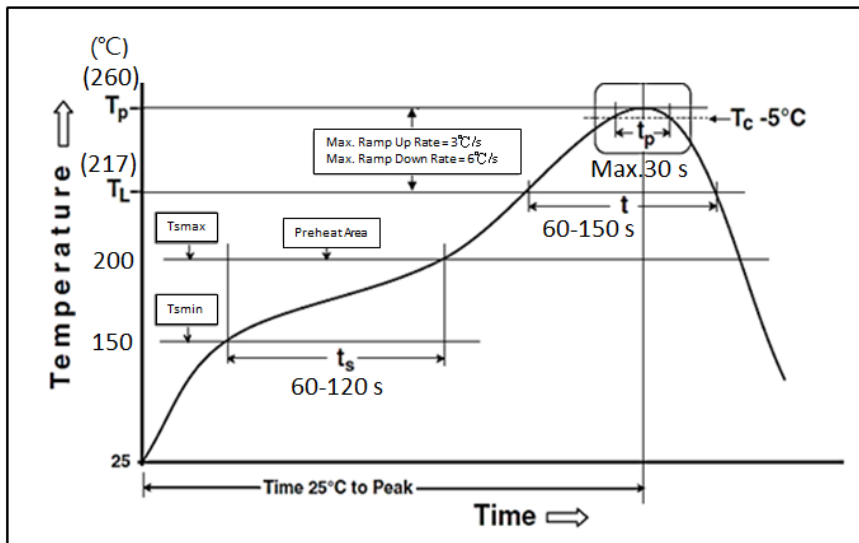

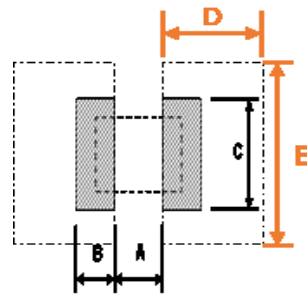
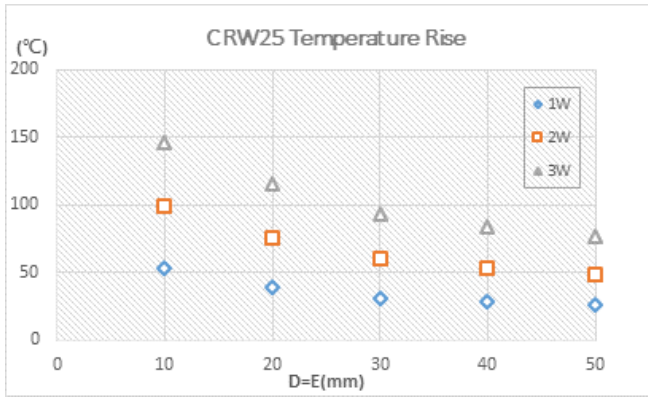

* FR4 copper board,
35μm of copper pad
thickness

Standard Electrical Specifications

Type	Item	Power Rating at 70°C Jumper Rated Current	Operating Temp. Range	Max. Operating Voltage	Max. Overload Voltage	Resistance Range			TCR (PPM/°C)
						±0.5% (E24,E96)	±1% (E24,E96)	±5% (E24)	
CRW08 (0508)		0.75W	-55 ~ +155°C	200V	400V	1Ω – 9.76Ω			±150
						10Ω – 1MΩ			±100
CRW62 (0612)		1W	-55 ~ +155°C	200V	400V	1Ω – 1MΩ			±100
CRW20 (1020)		1.5W	-55 ~ +155°C	200V	400V	1Ω – 9.76Ω			±150
						10Ω – 1MΩ			±100
CRW25 (1225)		2W	-55 ~ +155°C	200V	400V	1Ω – 29.4Ω			±200
						30Ω – 1MΩ			±100

High Power Rating Electrical Specifications

Type	Item	Power Rating at 70°C Jumper Rated Current	Operating Temp. Range	Max. Operating Voltage	Max. Overload Voltage	Resistance Range			TCR (PPM/°C)
						±0.5% (E24,E96)	±1% (E24,E96)	±5% (E24)	
CRW08 (0508)		1W Jumper: 5A	-55 ~ +155°C	200V	400V	1Ω – 9.76Ω			±150
						10Ω – 1MΩ			±100
						-	0Ω(<10mΩ)	-	
CRW62 (0612)		1.5W Jumper: 6A	-55 ~ +155°C	200V	400V	1Ω – 1MΩ			±100
						-	0Ω(<10mΩ)	-	
						1Ω – 9.76Ω			±150
CRW20 (1020)		2W Jumper: 10A	-55 ~ +155°C	200V	400V	10Ω – 1MΩ			±100
						-	0Ω(<10mΩ)	-	
						1Ω – 29.4Ω			±200
CRW25 (1225)		3W Jumper: 12A	-55 ~ +155°C	200V	400V	30Ω – 1MΩ			±100
						-	0Ω(<10mΩ)	-	
						1Ω – 9.76Ω			±150

Operating Voltage= $\sqrt{P \cdot R}$ or Max. Operating Voltage listed above, whichever is lower.
 Overload Voltage= $2.5 \cdot \sqrt{P \cdot R}$ or Max. Overload Voltage listed above, whichever is lower.
 ■ Viking is capable of manufacturing the optional spec based on customer's requirement.

Environmental Characteristics

Item	Requirement*	Test Method
Temperature Coefficient of Resistance (T.C.R.)	As Spec.	JIS-C-5201-1 4.8 IEC-60115-1 4.8 At 25°C/-55°C and 25°C/+125°C, 25°C is the reference temperature
Short Time Overload	±(1.0%+0.05Ω)	JIS-C-5201-1 4.13 IEC-60115-1 4.13 RCWV*2.5 or Max. Overload Voltage whichever is lower for 5 seconds
Insulation Resistance	≥10G	JIS-C-5201-1 4.6 IEC-60115-1 4.6 Max. Overload Voltage for 1 minute
Operational Life	±(1.0%+0.10Ω)	MIL-STD-202 Method 108 Condition D Steady State TA=125°C at derated power. Measurement at 24±4 hours after test conclusion.
Biased Humidity	±(1.0%+0.10Ω)	MIL-STD-202 Method 103 1000 hrs 85°C/85%RH 10% of operating power. (≤100 V)
High Temperature Exposure	±(1.0%+0.05Ω)	MIL-STD-202 Method 108 at +155°C for 1000 hrs
Board Flex	±(1.0%+0.05Ω)	AEC-Q200-005 Bending once for 60 seconds 3mm
Solderability	95% min. coverage	JIS-C-5201-1 4.17 IEC-60115-1 4.17 J-STD-002 245±5°C for 3 seconds
Resistance to Soldering Heat	±(0.5%+0.05Ω)	MIL-STD-202 Method 210 260±5°C for 10 seconds
Voltage Proof	No breakdown or flashover	JIS-C-5201-1 4.7 IEC-60115-1 4.7 1.42 times Max. Operating Voltage for 1 minute
Leaching	Individual leaching area ≤5% Total leaching area ≤ 10%	JIS-C-5201-1 4.18 IEC-60068-2-58 8.2.1 260±5°C for 30 seconds
Temperature Cycling	±(0.5%+0.05Ω)	JESD22 Method JA-104 -55°C to +125°C, 1000 cycles
Mechanical Shock	±(0.25%+0.05Ω)	MIL-STD-202 Method 213 Wave Form: Tolerance for half sine shock pulse. Peak value is 100g's. Normal duration (D) is 6.
Vibration	±(0.5%+0.05Ω)	MIL-STD-202 Method 204 5 g's for 20 min., 12 cycles each of 3 orientations, 10-2000 Hz
ESD	±(3%+0.05Ω)	AEC-Q200-002 Human body model: 2KV

Item	Requirement*	Test Method
Resistance to Solvents	No visible damage on appearance and marking.	MIL-STD-202 Method 215 Add Aqueous wash chemical - OKEM Clean or equivalent. Do not use banned solvents.
Terminal Strength	No broken	AEC-Q200-006 Force of 1.8kg for 60 seconds.
Flammability	No ignition of the tissue paper or scorching or the pinewood board	UL-94 V-0 or V-1 are acceptable. Electrical test not required.
Sulfur Test	$\Delta R \pm 1\%$	EIA-977 (Condition A) 60±2°C, no power rating for 500 hrs.

RCWV(Rated Continuous Working Voltage)= $\sqrt{(P \cdot R)}$ or Max. Operating Voltage whichever is lower.

* not include Jumper(0Ω)

■ **Storage Temperature: 15~28°C; Humidity < 80%RH**

■ **Packaging**

Reel Specifications & Packaging Quantity

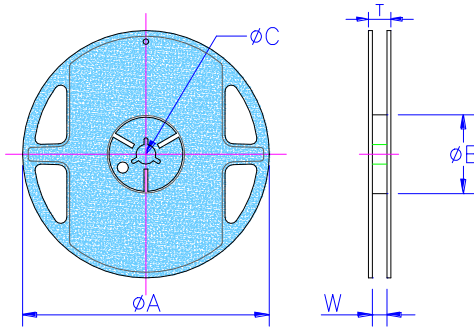

Type	Packaging Quantity		Tape Width	Reel Diameter	ΦA (mm)	ΦB (mm)	ΦC (mm)	W (mm)	T (mm)
CRW08 CRW62	Paper	5K	8mm	7 inch	178.5±1.5	60 ^{+1/-0}	13.0±0.2	9.0±0.5	12.5±0.5
CRW20 CRW25	Embossed	4K	12mm	7 inch	178.5±1.5	60 ^{+1/-0}	13.0±0.5	13.0±0.5	15.5±0.5

Paper Tape Specifications

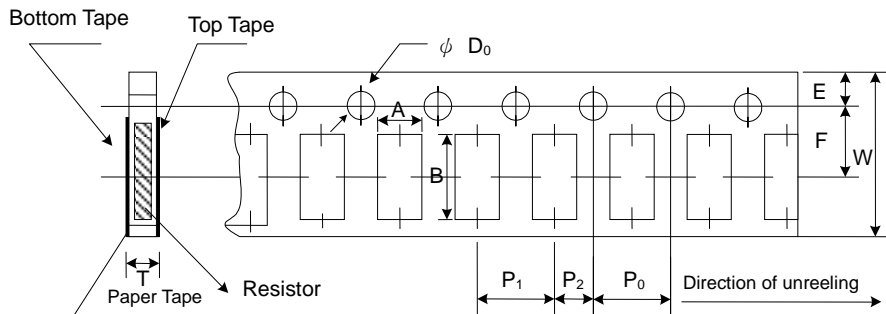

Type	A (mm)	B (mm)	W (mm)	E (mm)	F (mm)	P ₀ (mm)	P ₁ (mm)	P ₂ (mm)	ΦD ₀ (mm)	T (mm)
CRW08	1.60±0.10	2.40±0.20	8.0±0.20	1.75±0.10	3.50±0.05	4.00±0.10	4.00±0.05	2.00±0.05	1.50+0.1,-0	0.85±0.10
CRW62	1.90±0.10	3.50±0.20	8.0±0.20	1.75±0.10	3.50±0.05	4.00±0.10	4.00±0.05	2.00±0.05	1.50+0.1,-0	0.85±0.10

Embossed Plastic Tape Specifications

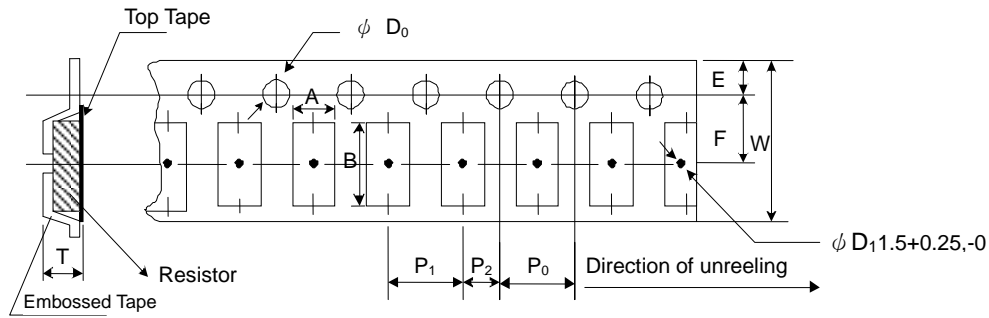

Type	A (mm)	B (mm)	W (mm)	E (mm)	F (mm)	P ₀ (mm)	P ₁ (mm)	P ₂ (mm)	ΦD ₀ (mm)	T (mm)
CRW20	2.80±0.15	5.40±0.20	12.0±0.10	1.75±0.10	5.5±0.05	4.00±0.05	4.00±0.10	2.00±0.05	1.55+0.10	1.00±0.20
CRW25	3.50±0.10	6.70±0.10	12.0±0.10	1.75±0.10	5.5±0.05	4.00±0.05	4.00±0.10	2.00±0.05	1.55+0.10	1.00±0.20

■ Marking

1% for 0508/0612/1020/1225: 4 digits marking

Example:

Resistance	20Ω	100Ω	1KΩ
Marking	20R0	1000	1001

5% for 0508/0612/1020/1225: 3 digits marking in E24

Example: 101=100Ω 102=1KΩ (1st and 2nd are E24 code and 3rd code is multiplier)

E24 code	10	11	12	13	15	16	18	20	22	24	27	30	33	36	39	43	47	51	56	62	68	75	82	91
----------	----	----	----	----	----	----	----	----	----	----	----	----	----	----	----	----	----	----	----	----	----	----	----	----

REVISION HISTORY

REVISION	DATE	CHANGE NOTIFICATION	DESCRIPTION
Version A	Oct 30, 2020	-	- New product release
Version A1	Nov 23, 2020	-	- Increase 1020/0508/0612 size and High power specifications
Version A2	Mar 10, 2021	-	- Increase 1020/0508/0612 Standard Electrical Specifications - Modify Soldering Condition