

LVAC Power Capacitors



FEATURES

- Self-healing technology
- Over pressure tear-off fuse
- Robust steel container
- Massive connection studs

APPLICATIONS

- Areas with dust and moisture, which require a high degree of protection and high creepage distances
- Free standing, fixed individual-PFC (e.g. motors, lighting, transformers)
- Automatic central-PFC (e.g. group of loads)
- Harmonic trap (e.g. UPS, frequency drives, converter)

QUICK REFERENCE DATA	
Series	PhMKP..., rectangular
Description	LVAC power capacitors - oil / dry - INDOOR , IP00 - IP43
Type	Capacitors, fixed, low voltage
Technology	MKP, metallized polypropylene film
Voltage max. (V)	690
Capacitance min. (μF)	3-phase D: 3 x 22.3
Capacitance max. (μF)	3-phase D: 3 x 663
Output min. (kvar)	10
Output max. (kvar)	100



CAPACITORS IN RECTANGULAR CASING

DESCRIPTION

ESTAprop PhMKP-type capacitors in rectangular steel casing have been designed for power factor correction in low voltage plants. Loads as motors and transformers consume real power as well as reactive power. Generators, supply cables, and other electrical distribution equipment should be relieved from reactive power.

DESIGN

The ESTAprop MKP capacitor in steel casing consists of a number of three-phase tubular can type capacitors (see PhMKP... Cylindrical Aluminum). The individual aluminum cans are wired together and mounted onto a steel frame. The steel frame together with the cans is housed in a common sheet steel casing. The supply cable may be connected at three threaded studs, on top of the capacitor. A threaded stud M10 for grounding is available. Easy mounting will be ensured by 4 drillings, at the bottom of the container.

This design ensures highest safety by:

- self-healing technology
- over pressure tear-off fuse
- robust steel container
- massive connection studs

RECTANGULAR CAPACITOR, IP43



RECTANGULAR CAPACITOR, BE-TYPE, IP00





TECHNICAL DATA	
STANDARDS	IEC 60831-1 + 2, EN 60831-1 + 2, LATEST EDITIONS
Overvoltages (in accordance with the above standards)	$U_{cn} + 10\%$ (up to 8 h daily) $U_{cn} + 15\%$ (up to 30 min daily) $U_{cn} + 20\%$ (up to 5 min, only 200 times in the life of the capacitor) $U_{cn} + 30\%$ (up to 1 min, only 200 times in the life of the capacitor) Please also refer to "Terms and Definitions".
Overcurrent (in accordance with the above standards)	$1.3 \times I_n$, $1.43 \times I_n$ with 10 % overvoltages, 10 % overcapacitance and harmonics included, continuous operation Please also refer to "Terms and Definitions".
Tolerance on capacitance	- 5 % / + 10 % in accordance with the standards ± 5 % as Vishay ESTA standard
Test voltage, terminal / terminal	$2.15 \times U_{cn}$, V_{AC} , 2 s (routine test)
Test voltage, terminal / casing	$4800 V_{AC}$, 2 s (routine test)
Inrush current	300 times rated current in
Losses	< 0.50 W/kvar
Statistical life expectancy ⁽¹⁾	> 100 000 operating hours
Degree of protection	IP00, IP43, indoor mounting
Permitted ambient temperature	-10 °C / B
Permitted casing temperature	Max. 60 °C (measured on top of the capacitor)
Cooling	Naturally air-cooled
Permissible relative humidity	Maximum 95 %
Maximum allowed altitude	2000 m above sea level
Mounting position	Vertical and horizontal
Mounting	4 drillings, Ø 9 mm, at the bottom of the container
Safety features	All-phase over pressure tear-off fuse, self-healing
Casing	Sheet steel casing, color RAL 7033
Dielectric	Polypropylene film, self-healing
Filling agent (of the tubular capacitors inside)	Natural oil, non-PCB, biodegradable (ESTAprop) or dry / gas - filled (ESTAdry)
Terminals	Threaded studs, M12

Note

⁽¹⁾ Statements about product lifetime are based on calculations and internal testing. They should only be interpreted as estimations. Also due to external factors, the lifetime in the field application may deviate from the calculated lifetime. In general, nothing stated herein shall be construed as a guarantee of quality or durability.

**CAPACITORS IN RECTANGULAR STEEL CASING, IP43**

RATED VOLTAGE 400 V ⁽¹⁾, 50 Hz, 3-PHASE, DELTA CONNECTION									
TYPE	ARTICLE NO. ⁽²⁾	OUTPUT kvar	CAPACITANCE μ F	CURRENT A (50 Hz)	DIMENSIONS L x W x H mm	PREVIOUS CABLE ENTRY	NEW CABLE ENTRY	WEIGHT kg	DRAWING NO.
PhMKP400/10	5342-42001-xx	10	3 x 66.3	14.4	260 x 135 x 525	LT21	M32	5	8
PhMKP400/12,5	5342-42002-xx	12.5	3 x 82.9	18	260 x 135 x 525	LT21	M32	5	8
PhMKP400/15	5342-42003-xx	15	3 x 99.5	21.6	260 x 135 x 525	LT21	M32	6	8
PhMKP400/16,7	5342-42004-xx	16.7	3 x 110.7	24.1	260 x 135 x 525	LT21	M32	6	8
PhMKP400/20	5342-42005-xx	20	3 x 133	28.9	260 x 135 x 525	LT21	M32	6.5	8
PhMKP400/25	5342-42006-xx	25	3 x 166	36	260 x 135 x 525	LT21	M32	6.5	8
PhMKP400/30	5342-42007-xx	30	3 x 199	43.3	260 x 135 x 525	LT29	M40	8	8
PhMKP400/33,3	5342-42008-xx	33.3	3 x 221	48	260 x 135 x 525	LT29	M40	8	8
PhMKP400/40	5342-42009-xx	40	3 x 265	57.7	260 x 135 x 525	LT29	M40	9	8
PhMKP400/50	5342-42010-xx	50	3 x 332	72.2	260 x 135 x 525	LT29	M40	10	8
PhMKP400/60	5342-42011-xx	60	3 x 398	86.6	260 x 135 x 525	LT36	M50	11	8
PhMKP400/66,7	5342-42012-xx	66.7	3 x 442	96.3	260 x 135 x 525	LT36	M50	12.5	8
PhMKP400/70	5342-42013-xx	70	3 x 464	101	395 x 135 x 525	LT36	M50	13	8
PhMKP400/75	5342-42014-xx	75	3 x 497	108	395 x 135 x 525	LT36	M50	14	8
PhMKP400/83,3	5342-42015-xx	83.3	3 x 552	120	395 x 135 x 525	LT36	M50	15	8
PhMKP400/100	5342-42016-xx	100	3 x 663	144	395 x 135 x 525	LT42	M63	17	8

CAPACITORS IN RECTANGULAR STEEL CASING, IP00

RATED VOLTAGE 400 V ⁽¹⁾, 50 Hz, 3-PHASE, DELTA CONNECTION							
TYPE	ARTICLE NO. ⁽²⁾	OUTPUT kvar	CAPACITANCE μ F	CURRENT A (50 Hz)	DIMENSIONS L x W x H mm	WEIGHT kg	DRAWING NO.
PhMKP400/10BE	5342-42121-xx	10	3 x 66.3	14.4	260 x 135 x 418	5	9
PhMKP400/12,5BE	5342-42122-xx	12.5	3 x 82.9	18	260 x 135 x 418	5	9
PhMKP400/15BE	5342-42123-xx	15	3 x 99.5	21.6	260 x 135 x 418	6	9
PhMKP400/16,7BE	5342-42124-xx	16.7	3 x 110.7	24.1	260 x 135 x 418	6	9
PhMKP400/20BE	5342-42125-xx	20	3 x 133	28.9	260 x 135 x 418	6.5	9
PhMKP400/25BE	5342-42126-xx	25	3 x 166	36	260 x 135 x 418	6.5	9
PhMKP400/30BE	5342-42127-xx	30	3 x 199	43.3	260 x 135 x 418	8	9
PhMKP400/33,3BE	5342-42128-xx	33.3	3 x 221	48	260 x 135 x 418	8	9
PhMKP400/40BE	5342-42129-xx	40	3 x 265	57.7	260 x 135 x 418	9	9
PhMKP400/50BE	5342-42130-xx	50	3 x 332	72.2	260 x 135 x 418	10	9
PhMKP400/60BE	5342-42131-xx	60	3 x 398	86.6	260 x 135 x 418	11	9
PhMKP400/66,7BE	5342-42132-xx	66.7	3 x 442	96.3	260 x 135 x 418	12.5	9
PhMKP400/70BE	5342-42133-xx	70	3 x 464	101	395 x 135 x 418	13	9
PhMKP400/75BE	5342-42134-xx	75	3 x 497	108	395 x 135 x 418	14	9
PhMKP400/83,3BE	5342-42135-xx	83.3	3 x 552	120	395 x 135 x 418	15	9
PhMKP400/100BE	5342-42136-xx	100	3 x 663	144	395 x 135 x 418	17	9

Notes

- Other voltage ratings, outputs, and frequencies upon request.
All PhMKP-type capacitors may be used for 60 Hz, the output will be 1.2 times higher.
 - All oil-impregnated part types can also be produced in a PhMKPg dry version. Dimensions and ratings are unchanged.
Dry types are not standard stock items, with production upon request.
- (1) Can be used also for 415 V, with full overvoltage range.
(2) Version no. xx may differ as it respects small changes, e.g. on the label.

DIMENSIONS

Drawing 8

Rectangular-type capacitor,
three phase, IP43

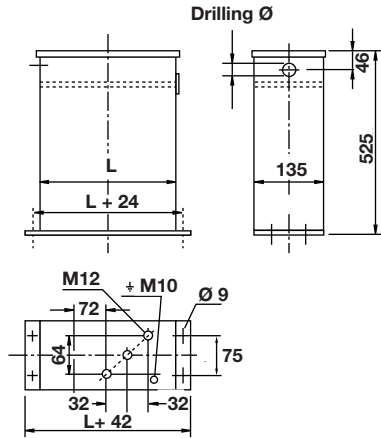

Drawing 9

Rectangular-type, BE-capacitor,
three phase, IP00 418 mm high

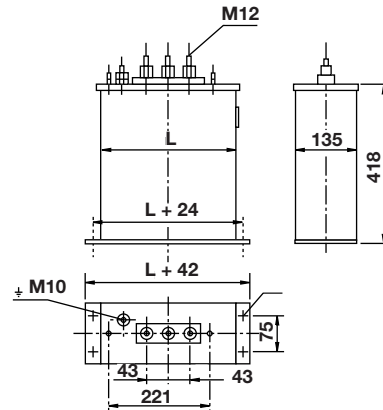

RECOMMENDED TORQUES	
TERMINAL STYLE	RECOMMENDED TORQUE
Terminals M6	3 Nm
Terminals M8	6 Nm
Terminals M10	10 Nm
Terminals M12	15.5 Nm

CABLE GLANDS AND GASKETS				
OUTPUT IN kvar / 400 V, 50 Hz	PG	DRILLING Ø IN mm (PG)	M	DRILLING Ø IN mm (M)
10 to 25	21	28.5	32	34
30 to 50	29	38	40	42
60 to 83.3	36	48	50	50.5
100	42	55	63	63.5

ORDERING INFORMATION	
MINIMUM ORDER QUANTITY PER TYPE AND ORDER	DELIVERY TIME
1 unit	Delivery time is approximately 4 weeks



Disclaimer

ALL PRODUCT, PRODUCT SPECIFICATIONS AND DATA ARE SUBJECT TO CHANGE WITHOUT NOTICE TO IMPROVE RELIABILITY, FUNCTION OR DESIGN OR OTHERWISE.

Vishay Intertechnology, Inc., its affiliates, agents, and employees, and all persons acting on its or their behalf (collectively, "Vishay"), disclaim any and all liability for any errors, inaccuracies or incompleteness contained in any datasheet or in any other disclosure relating to any product.

Vishay makes no warranty, representation or guarantee regarding the suitability of the products for any particular purpose or the continuing production of any product. To the maximum extent permitted by applicable law, Vishay disclaims (i) any and all liability arising out of the application or use of any product, (ii) any and all liability, including without limitation special, consequential or incidental damages, and (iii) any and all implied warranties, including warranties of fitness for particular purpose, non-infringement and merchantability.

Statements regarding the suitability of products for certain types of applications are based on Vishay's knowledge of typical requirements that are often placed on Vishay products in generic applications. Such statements are not binding statements about the suitability of products for a particular application. It is the customer's responsibility to validate that a particular product with the properties described in the product specification is suitable for use in a particular application. Parameters provided in datasheets and / or specifications may vary in different applications and performance may vary over time. All operating parameters, including typical parameters, must be validated for each customer application by the customer's technical experts. Product specifications do not expand or otherwise modify Vishay's terms and conditions of purchase, including but not limited to the warranty expressed therein.

Hyperlinks included in this datasheet may direct users to third-party websites. These links are provided as a convenience and for informational purposes only. Inclusion of these hyperlinks does not constitute an endorsement or an approval by Vishay of any of the products, services or opinions of the corporation, organization or individual associated with the third-party website. Vishay disclaims any and all liability and bears no responsibility for the accuracy, legality or content of the third-party website or for that of subsequent links.

Except as expressly indicated in writing, Vishay products are not designed for use in medical, life-saving, or life-sustaining applications or for any other application in which the failure of the Vishay product could result in personal injury or death. Customers using or selling Vishay products not expressly indicated for use in such applications do so at their own risk. Please contact authorized Vishay personnel to obtain written terms and conditions regarding products designed for such applications.

No license, express or implied, by estoppel or otherwise, to any intellectual property rights is granted by this document or by any conduct of Vishay. Product names and markings noted herein may be trademarks of their respective owners.